

# KANO<sup>510</sup>™ HD

## MACHINE DIMENSIONS

|                           |            |
|---------------------------|------------|
| Effective cutting width   | (A) 60"    |
| Effective cutting length  | (B) 120"   |
| Overall machine width     | (C) 116.3" |
| Overall machine length    | (D) 198"   |
| Overall machine height    | (E) 78"    |
| Cutting table slat height | (F) 36.7"  |

**NOTE:** Maximum cutting area 64" W x 124" L

**NOTE:** Overall machine width when Operator Control Station is swung inward is 98.137"

**NOTE:** Machine dimensions exclude plasma system, equipment stands and dust collector

**NOTE:** Standard configuration is with the Operator Control Station mounted on front left corner of the machine

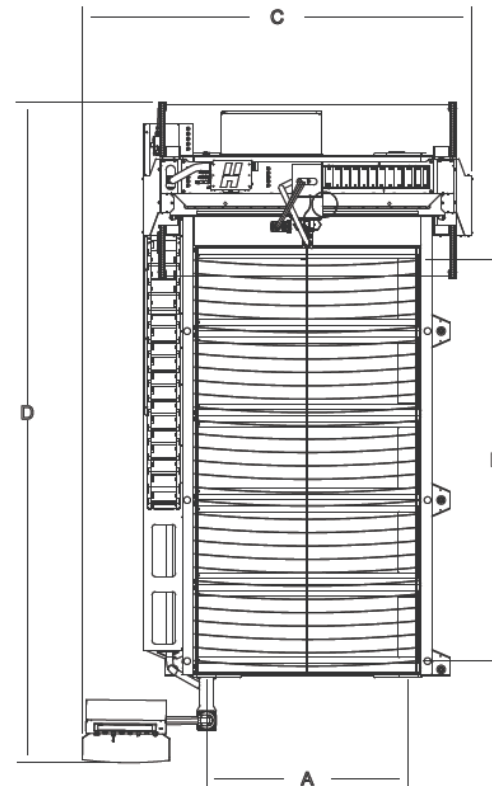
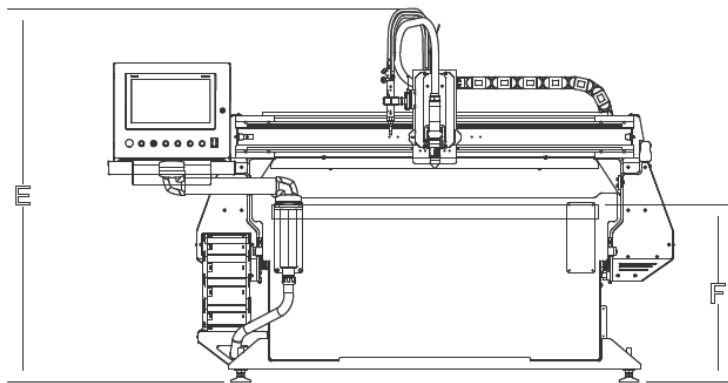

6301 Saukview Dr., St. Cloud, MN 56303  
800.328.2309 | parkindustries.com